

## Sensor and Simulation Notes VII

### Characteristics of the Moibus Strip Loop

#### I. Introduction

The typical loop used for measuring the time derivative of the magnetic field,  $\dot{B}$ , is constructed from two pieces of coaxial cable which drive a balanced cable (twinax) and have only their center conductors joined to close the loop. This kind of loop is shown in Figure 1. However it is possible to improve upon this for some applications by use of what can be called a moibus strip loop (to be described later) which has the properties of doubled sensitivity to the magnetic field but much less sensitivity to transient radiation effects.

Throughout this note the more typical loop configuration which can be called a split shield loop will be discussed first, for purposes of comparison with the moibus strip loop. Comparison will be made both for the electrical characteristics and the radiation characteristics.

#### II. Electrical Characteristics

##### A. Split Shield Loop

In Figure 1 the pertinent electric parameters are shown for the split shield loop. The compton current sources ( $I_{C_L}$  and  $I_{C_R}$ ) are also shown and will be discussed later.

One can see how this sensor works most easily from symmetry considerations. A voltage,  $V$ , equal to the product of the loop area and  $\dot{B}$ , is impressed across the gap in the coaxial shields at the top of the loop. The coaxial cables each are equivalently a resistive load of value  $Z/2$  and these loads are in series with one another as shown in Figure 2. The voltage then divides equally into the two coaxial lines and for the symmetrical system shown in Figure 1 the two waves combine to give the original voltage  $V$  in a twinax cable of impedance  $Z$ . This particular structure has been thoroughly discussed by L. L. Libby in Special Aspects of Balanced Shielded Loops, I. R. E., Sept. 1946.

One point which should be discussed here is the matching of the coaxial cables into the twinax so that reflections will not be propagated from this junction back to the opening in the coaxial lines at the top of the loop. If one considers only the differential signal,  $V_s$ , arriving at the coax to twinax junction, then with no common mode signal to propagate down the twinax this junction can be considered as in Figure 3.

CLEARED  
FOR PUBLIC RELEASE

PL/PA 26 Oct 94  
1

PL 94-0856

## Sensor and Simulation Notes VII

### Characteristics of the Moibus Strip Loop

#### I. Introduction

The typical loop used for measuring the time derivative of the magnetic field,  $\dot{B}$ , is constructed from two pieces of coaxial cable which drive a balanced cable (twinax) and have only their center conductors joined to close the loop. This kind of loop is shown in Figure 1. However it is possible to improve upon this for some applications by use of what can be called a moibus strip loop (to be described later) which has the properties of doubled sensitivity to the magnetic field but much less sensitivity to transient radiation effects.

Throughout this note the more typical loop configuration which can be called a split shield loop will be discussed first, for purposes of comparison with the moibus strip loop. Comparison will be made both for the electrical characteristics and the radiation characteristics.

#### II. Electrical Characteristics

##### A. Split Shield Loop

In Figure 1 the pertinent electric parameters are shown for the split shield loop. The current sources ( $I_{CL}$  and  $I_{CR}$ ) are also shown and will be discussed later.

One can see how this sensor works most easily from symmetry considerations. A voltage,  $V$ , equal to the product of the loop area and  $\dot{B}$ , is impressed across the gap in the coaxial shields at the top of the loop. The coaxial cables each are equivalently a resistive load of value  $Z/2$  and these loads are in series with one another as shown in Figure 2. The voltage then divides equally into the two coaxial lines and for the symmetrical system shown in Figure 1 the two waves combine to give the original voltage  $V$  in a twinax cable of impedance  $Z$ . This particular structure has been thoroughly discussed by L. L. Libby in Special Aspects of Balanced Shielded Loops, I. R. E., Sept. 1946.

One point which should be discussed here is the matching of the coaxial cables into the twinax so that reflections will not be propagated from this junction back to the opening in the coaxial lines at the top of the loop. If one considers only the differential signal,  $V_s$ , arriving at the coax to twinax junction, then with no common mode signal to propagate down the twinax this junction can be considered as in Figure 3.

The differential signal appears across the twinax impedance,  $Z$ , which can be considered as two resistors each of value  $Z/2$  in series. Since the voltage in one coax is exactly the negative of the voltage in the second coax the point between these two resistors is at zero voltage and can therefore be connected to the shield. Now one can see that each coax (in this differential mode) is terminated in its characteristic impedance and that there are no reflections. This technique can of course be generalized to calculate the transmission and reflection coefficients for any combination of coax and twinax impedances.

This impedance matching property is an important one for all shielded loops including the split shield loop and the moibus strip loop considered in this note. One should observe that this property holds only for the differential signals. Fortunately for cases of interest, where the loop is a balanced device, the response to the magnetic field is a differential signal. This condition holds for both the split shield loop and the moibus strip loop. Another important characteristic of the split shield loop is its rise time to a step  $\vec{B}$  input. As shown above, the loop is driving a resistive impedance  $Z$ . This implies a time constant for this loop,  $\tilde{\tau}_1$ ,

$$\tilde{\tau}_1 = L/Z \quad (1)$$

and in turn a rise time,  $\tilde{\tau}_{r1}$ ,

$$\tilde{\tau}_{r1} \approx 2\tilde{\tau}_1 = 2L/Z \quad (2)$$

This approximation is only valid if the round trip transit time on the loop structure is less than this calculated rise time.

The important thing to remember about this loop is that it is effectively a single turn loop with a time constant  $L/Z$ .

## B. Moibus Strip Loop

Figure 4 is a drawing of the moibus strip loop. The only difference in construction from a split shield loop is at the top of the loop where the split occurs and the signal enters the coaxial lines. In the moibus strip loop, the center conductors from the two coaxial lines are not joined together but are each connected to the shield of the opposite coaxial line. The difference which this change makes is first demonstrated by tracing the loop itself. Starting at letter A on the left twinax conductor, one can trace a path up the center conductor of the left arm of the loop to point B and from there to point D on the shield of the right arm. Travelling on the shield then one goes around the loop to point C on the shield of the left arm and then to point E on the center conductor of the right arm. Finally one can trace the path down the center conductor of the right arm to the right twinax conductor. The path traced constitutes effectively a two-turn loop and as such should have double the sensitivity of a single turn loop. Thus if  $V$  is the potential generated by  $\dot{B}$  around a single turn loop of this size, the potential appearing around this moibus strip loop should be  $2V$ .

Moreover, in Figure 5, note that the two coaxial cable arms now have their impedances in parallel at the gap whereas in Figure 2 the split shield loop has these loads presented in series. This means that for frequency response calculations one can consider the moibus strip loop as an inductance  $L$  with an impedance  $Z/4$ . This implies a time constant,  $\tau_2$ , for this loop

$$\tau_2 = 4 L/Z \quad (3)$$

Thus, for the same loop structure and cable impedances (neglecting transit time effects on the loop structure), the frequency response of the moibus strip loop is one fourth that of the split shield loop.

In addition, the fact that the coaxial lines are connected in parallel at the gap implies that the full voltage,  $V$ , at the gap is impressed across each coax, but with opposite polarity in each coaxial line. Now when the waves reach the twinax the difference will be  $2V$  confirming the earlier argument based on consideration of the moibus strip loop as a two turn loop.

The important electrical characteristics of the moibus strip loop are then its doubled sensitivity and its quartered frequency response. However, this last limitation can be overcome by lowering the loop inductance to the point where the transit time on the loop structure is the limiting factor, giving both loops the same frequency response. This aspect of loop design will be discussed in another sensor note.

### III. Compton Current Effects

#### A. General

From the viewpoint of EMP measurements reduction of radiation induced noise signals are more important than enhanced sensitivity to B. Of course this can all be put together as an optimization of the signal-to-noise ratio, but the point to be made is that some analysis is needed of the radiation induced electrical signals in the cables.

Basically each segment of cable acts as a Compton diode in a gamma radiation field. Negative charge is collected on the center conductor since more high energy electrons stop in the center conductor than are driven from it because of the gamma attenuation in this center conductor. In addition, if the cable dielectric is hydrogenous (e.g. polyethylene), the center conductor will collect neutron scattered protons further complicating the picture. The signals produced by these currents depend on the geometry of the sensor and the quality of the differencing techniques used.

#### B. Split Shield Loop

For the split shield loop in Figure 1, the compton current is represented as a current source in each arm of the loop. Since the center conductors of the cables are not connected to the outer shields, this compton current must go down the center conductors of the twinax. If  $Z'$  is defined as the common mode impedance of the twinax (i.e., the ratio of the average value of the voltages on the center conductors to the vector sum of the currents on these conductors) then there is a common mode voltage,  $V_{com}$ , given by

$$V_{com} = (I_{c_L} + I_{c_R}) Z'$$

(4)

In general if the transit time characteristic of the loop dimensions can be neglected then the split shield loop can be represented by the equivalent circuit given in Figure 6.  $V_L$  and  $V_R$  are respectively the voltages on the left and right twinax leads.  $V_R - V_L$  represents any differential voltages present and  $V_L + V_R$  represents the common mode voltages. From this equivalent circuit, equation (4) can be derived as well as some other relations. For example the inductance of the loop and any difference in the Compton currents in the two arms, will produce a differential signal,  $V_{dif}$ , given by

$$V_{dif} = (V_R - V_L) \Big|_{V=0} = \left( \frac{I_{cR} - I_{cL}}{2} \right) \left( \frac{j\omega L}{Z + j\omega L} \right) Z \quad (5)$$

assuming for this calculation that  $V = 0$  and that  $I_{cR}$  and  $I_{cL}$  are both the Fourier components of the Compton currents at radian frequency  $\omega$ . Therefore, if the two coaxial cables have different radiation sensitivities or if one cable shadows the other from the radiation, the loop inductance will cause this Compton current difference to appear as a differential noise signal given by equation (5).

As the pulse width approaches the transit times characteristic of the loop the above approximations will break down. The loop structure must be considered not a lumped inductance but a shorted transmission line as Libby has shown in the previously referenced article. Also the coaxial lines which form the loop have finite length and the Compton current signal is thus distributed in space and time. The radiation signal may arrive at the two coaxial lines at different times depending on the loop orientation, and introduce another differential signal.

In summary, the split shield loop has the radiation noise characteristics of (1) a common mode signal proportional to the radiation intensity, and (2) a differential signal proportional to any differences in the radiation induced current for frequencies greater than  $Z/L$  or greater than the reciprocal of the time constants characteristic of the loop. As shown in the consideration of the Moibus strip loop, the second characteristic will also be present but the first will be greatly modified.

### C. Moibus Strip Loop

For the moibus strip loop in Figure 4, the compton current is again represented as a current source in each arm of the loop. In contrast to the split shield loop, however, the center conductors of both coaxial lines are connected to the outer shields thus allowing the compton currents to be shorted out at the loop instead of being driven down the twinax to the recording instruments. Of course the loop inductance plays a role in this as shown in the low frequency equivalent circuit of the moibus strip loop in Figure 7. In this case the common mode signal is identically zero, i.e.,

$$V_R + V_L = 0 \quad (6)$$

This last equation is true assuming the transition between the two coaxial lines at the top of the loop is reflectionless (See Figure 3) so that the compton signal generated in one line can propagate into the other line, reversing sign in the process. This zero common mode signal also assumes frequencies lower than the reciprocal of the transit times in the coaxial lines. As an approximation, if the transit time in one of the coaxial lines is  $t_r$  and the radiation current is considered to be generated uniformly throughout the coaxial lines, then the common mode current,  $I_{com}$ , can be calculated to be

$$I_{com} \approx t_r \frac{\partial}{\partial t} \left( \frac{I_{cR} + I_{cL}}{2} \right) \quad (7)$$

The factor of 2 in the currents arises since the compton current source at any given point sets up a wave in both directions in the cable.

The corresponding common mode voltage,  $V_{com}$ , is

$$V_{com} \approx Z' t_r \frac{\partial}{\partial t} \left( \frac{I_{cR} + I_{cL}}{2} \right) \quad (8)$$

There are other corrections which can be made to these expressions for the common mode signal involving the common mode transmission and reflection coefficients at this junction which will cause currents to flow back around the loop and be reinverted in the process. However, the form of this correction will depend on the form chosen for the common currents and again the time derivative of these currents. To estimate the common mode signals with greater accuracy than eqns. (7) and (8) requires a detailed consideration of the loop geometry and the form chosen for the common currents.

This common mode signal is much smaller than that for the split shield loop, and as the loop dimensions are decreased (lowering  $t_r$ ) the common mode signal from the moibus strip loop then becomes much smaller than that from the split shield loop.

The differential radiation noise signal,  $V_{dif}$ , can be calculated for the moibus strip loop from the equivalent circuit in Figure 7 giving a result similar to that for the split shield loop.

$$\begin{aligned}
 V_{dif} &= 2(I_{c_R} - I_{c_L}) \frac{j\omega L Z/4}{Z/4 + j\omega L} \\
 &= \left( \frac{I_{c_R} - I_{c_L}}{2} \right) Z \frac{j\omega L}{Z/4 + j\omega L} \\
 &= \left( \frac{I_{c_R} - I_{c_L}}{2} \right) Z \frac{j\omega(4L)}{Z + j\omega(4L)}
 \end{aligned}$$

(9)

This result is similar to eqn (5) except that the rolloff frequency is only one fourth as high. However, this same characteristic has already appeared in the electrical characteristics of this loop and it shows that reduction of the inductance of the moibus strip loop to maximize the frequency response to the transit time limitations will reduce the differential noise signal to these limitations.



In principle the differential radiation noise signals for both the split shield loop and the moibus strip loop can be reduced to the same level determined by the transit time characteristics of the loops.

#### IV. Conclusions

For the same loop area the moibus strip loop has twice the  $\dot{B}$  sensitivity of the split shield loop but has a lower frequency response for the same loop inductance. More important, the moibus strip loop greatly reduces the common mode radiation noise currents found in the split shield loop and can be made to have the same low differential radiation noise signal (using symmetrical construction, etc.) as the split shield loop.

CARL E. BAUM, 1/LT, USAF  
3 December 1964

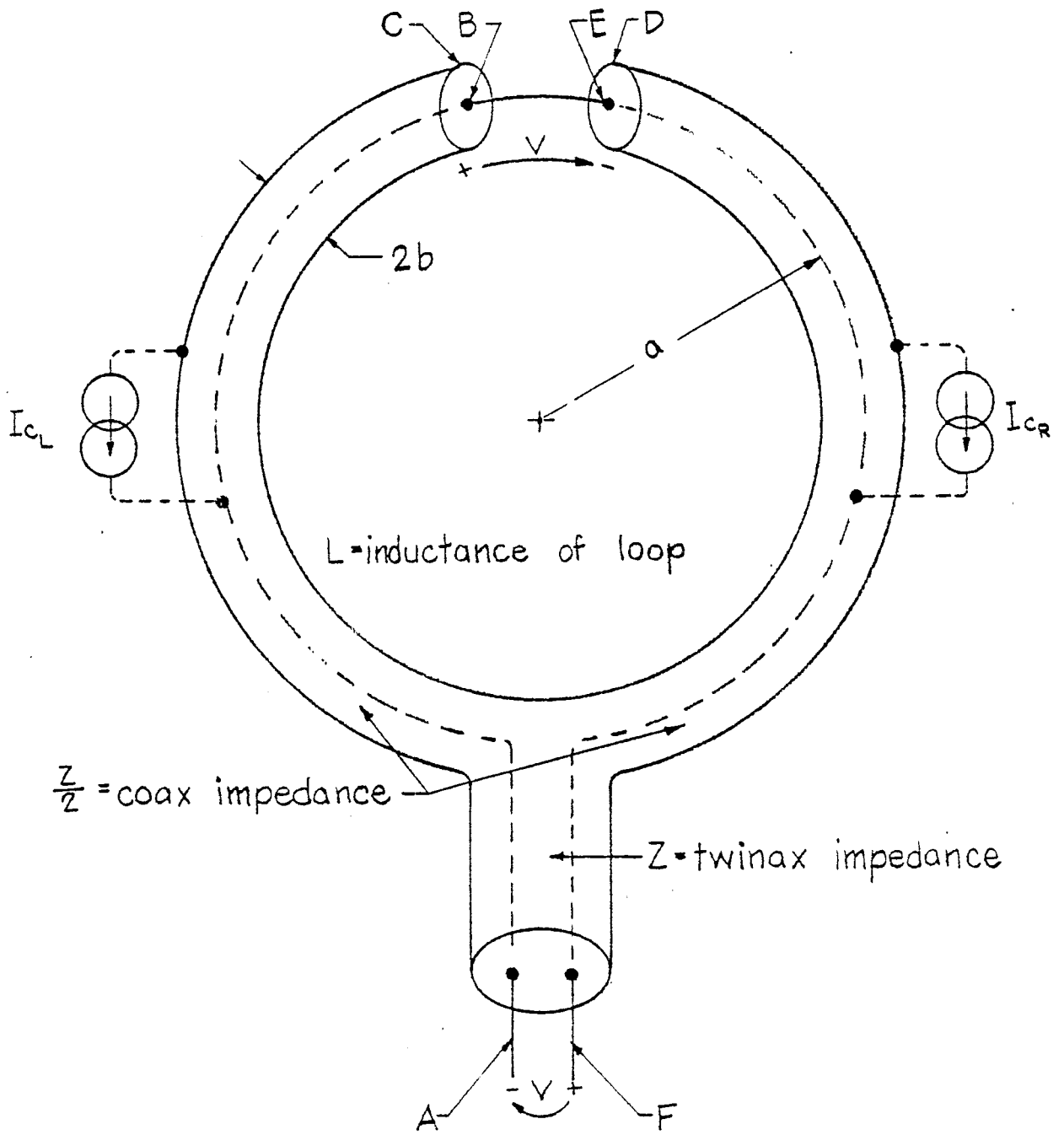

Fig.1 Split Shield Loop

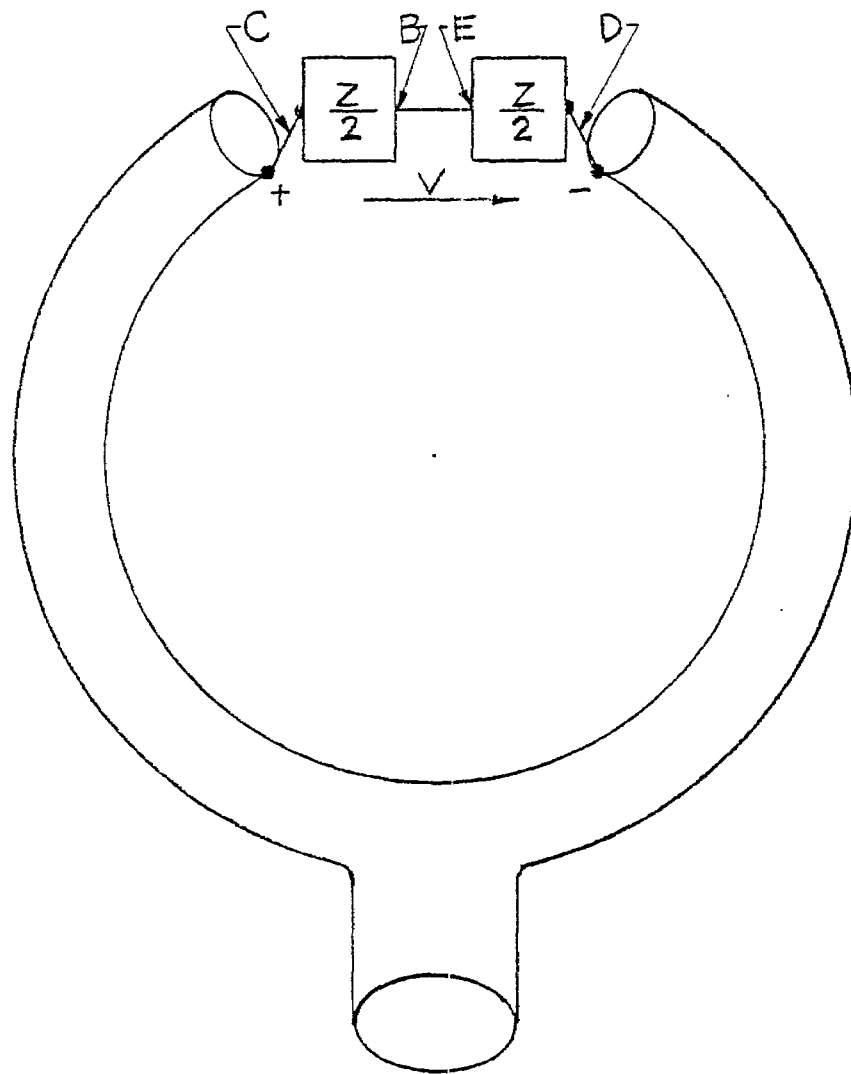
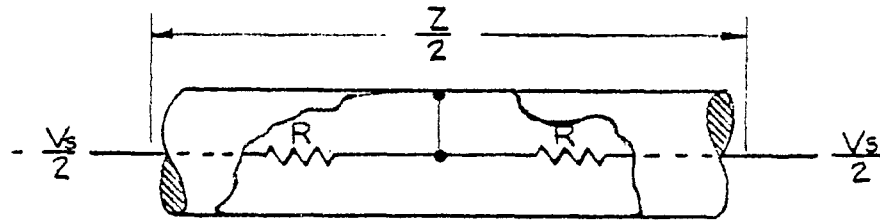
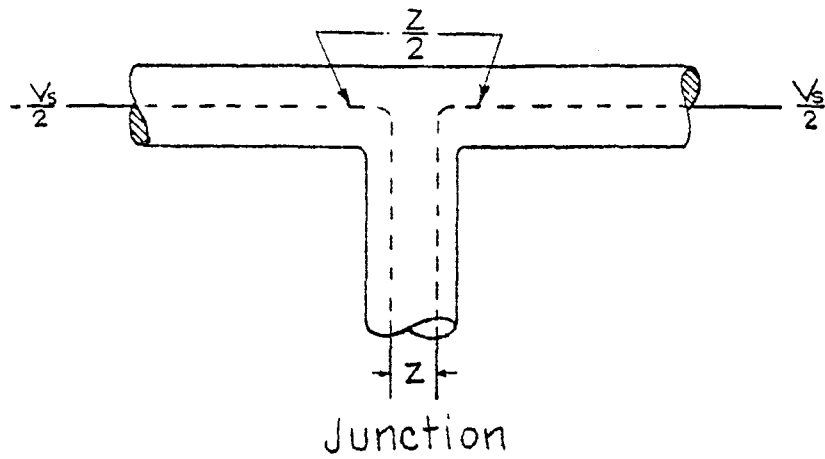

Fig. 2 Load for Split Shield Loop



$$2R = Z$$

$R$  = equivalent terminating resistor

Equivalent Circuit

Fig. 3 Differential Signal at Coax to Twinax Junction

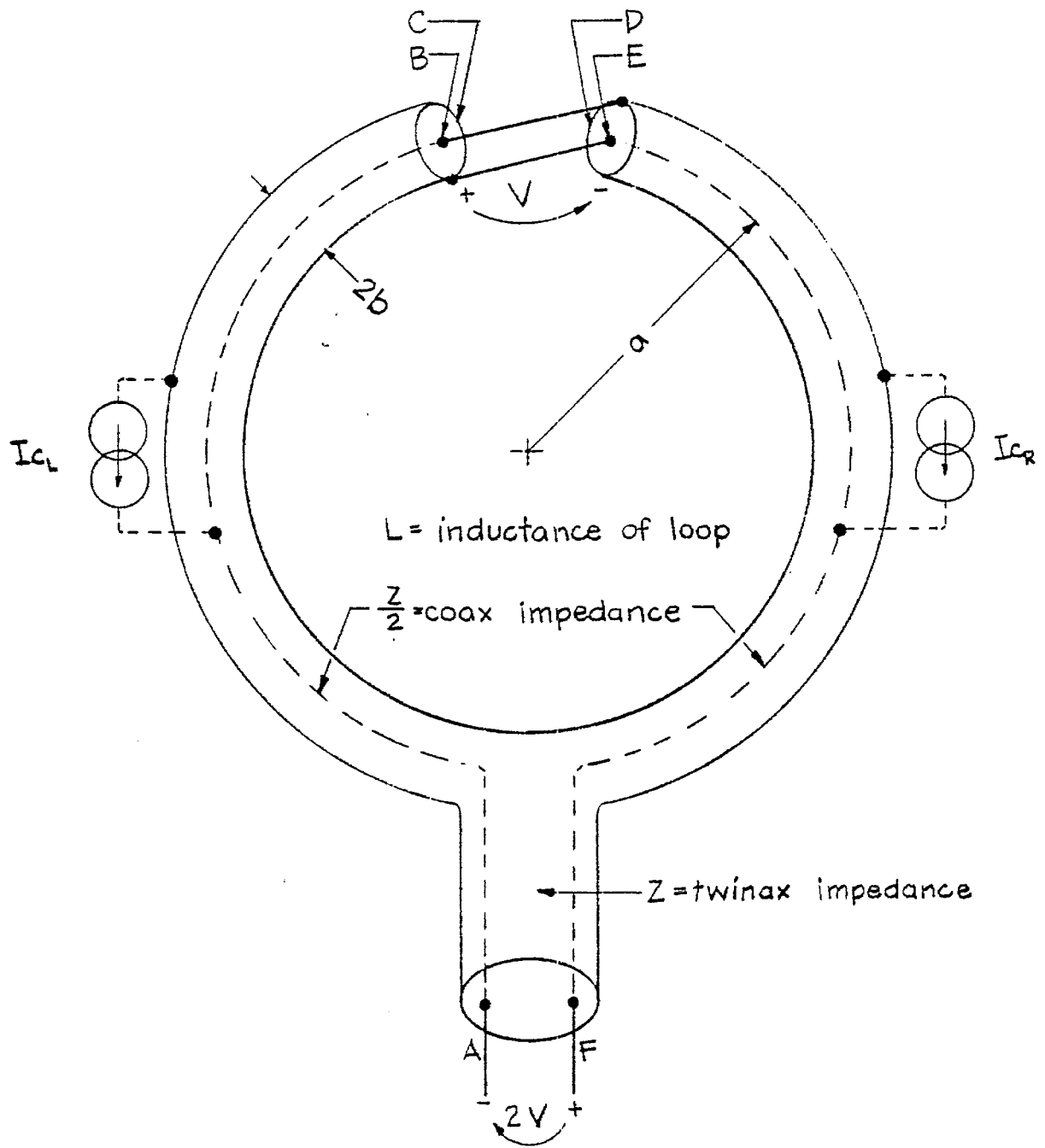

Fig.4 Moibus Strip Loop

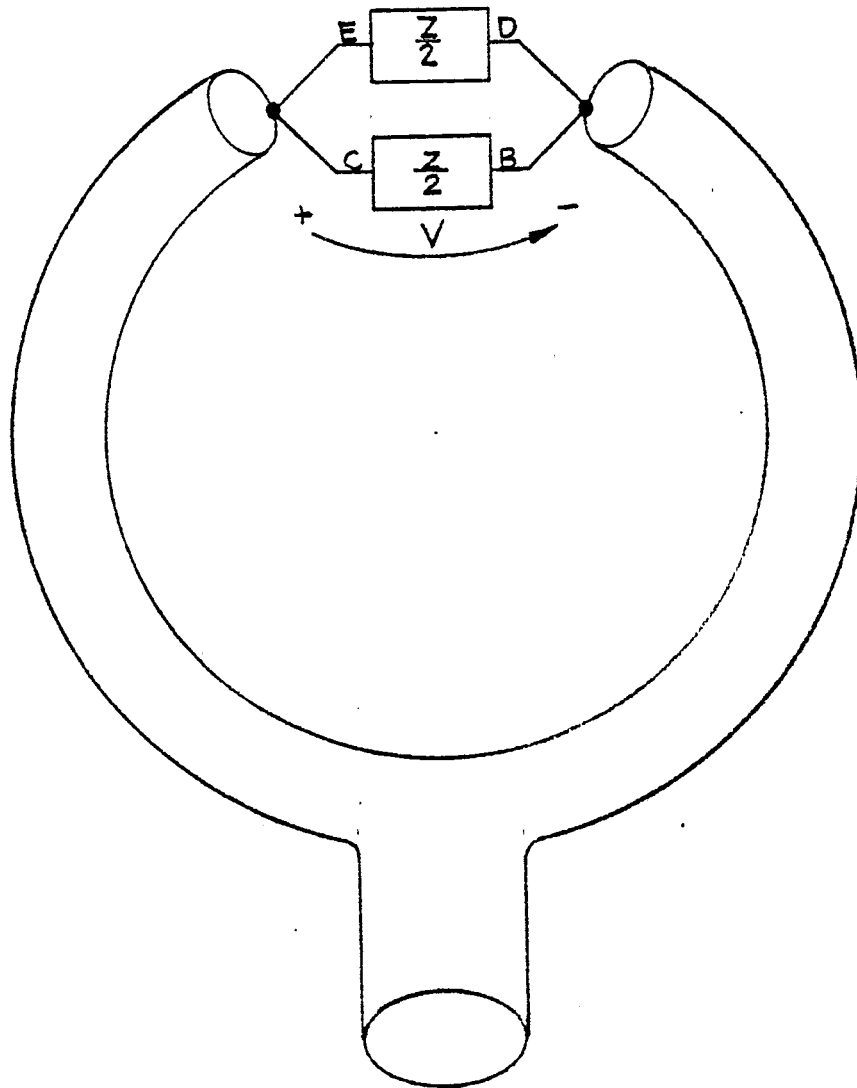
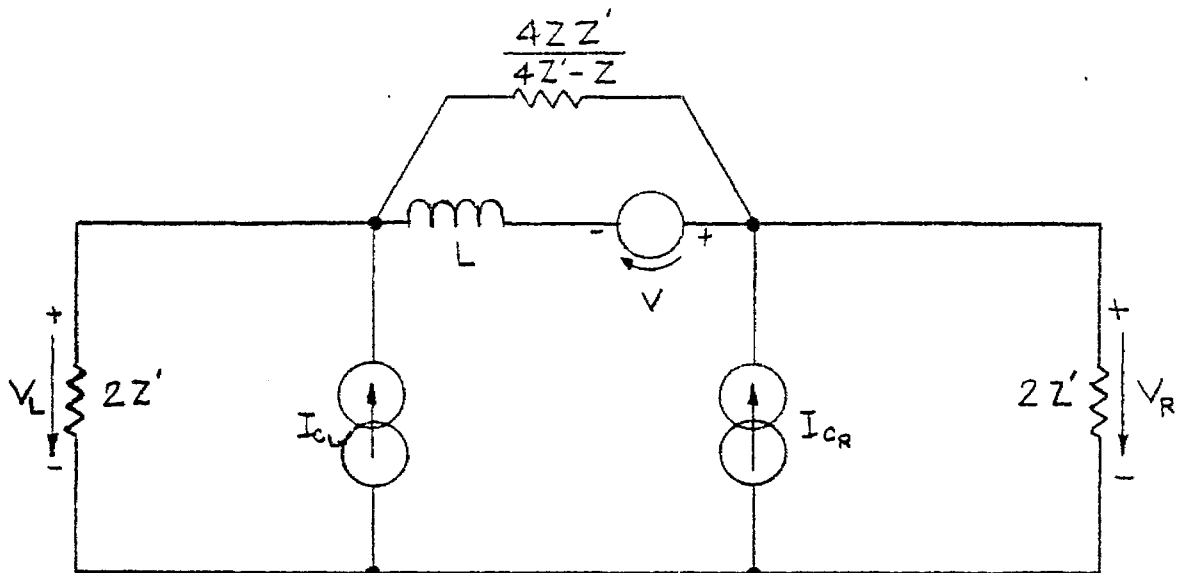
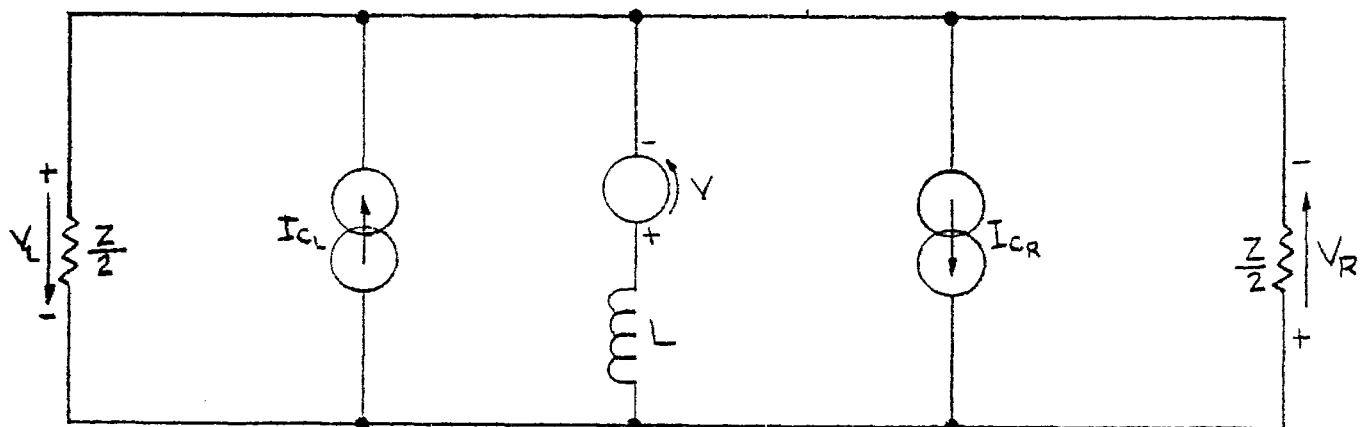

Fig.5 Load for Moibus Strip Loop



$Z$  = differential twinax impedance  
 $Z'$  = common mode twinax impedance

Fig. 6 Equivalent Circuit for Split Shield Loop  
 (Neglecting Transit Times)



$Z$  = differential twinax impedance

Fig. 7 Equivalent Circuit for Moibus Strip Loop  
 (Neglecting Transit Times)